

Air/Oil Compensators



Description

Used as additional tank or as aid of pressure intensifier in cases where the multiplier does not move a sufficient volume of oil to operate cylinders with superior capabilities to those available. Magnetic version available with position sensors, regulating unit with manometer.

2 proposed diameter: Ø100 et Ø160.

Capacity for Ø100 : 1,2 and 3 Liters

Capacity for Ø160 : 4,5,8 and 10 Liters

Version with movable piston and Version with Fixed piston.

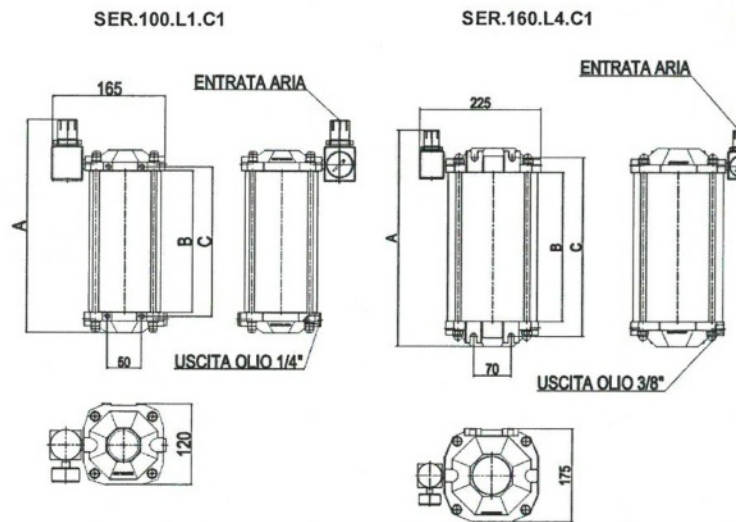
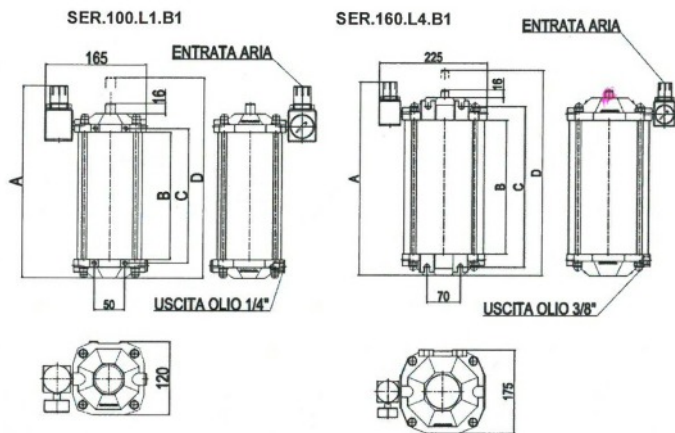

Modèle	A	B	C	D
SER.100.L.1.B	315	210	222	450
SER.100.L.2.B	445	335	347	580
SER.100.L.3.B	575	465	477	710
SER.160.L.4.B	405	280	335	630
SER.160.L.5.B	455	330	385	680
SER.160.L.8.B	605	480	535	820
SER.160.L.10.B	705	580	635	920

Modèle	A	B	C
SER.100.L.1.C	315	210	222
SER.100.L.2.C	445	335	347
SER.100.L.3.C	575	465	477
SER.160.L.4.C	405	280	335
SER.160.L.5.C	455	330	385
SER.160.L.8.C	605	480	535
SER.160.L.10.C	705	580	635

Subject to technical modifications