

PMPO BASE VERSION

With oil discharge (S)

COURBE

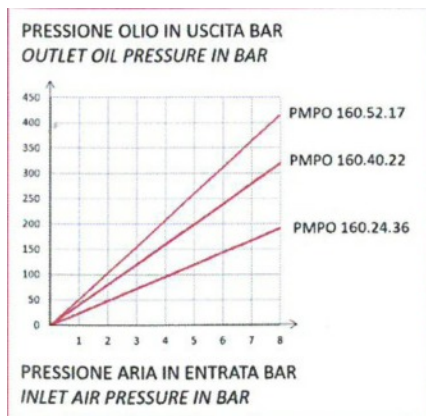

Symbole

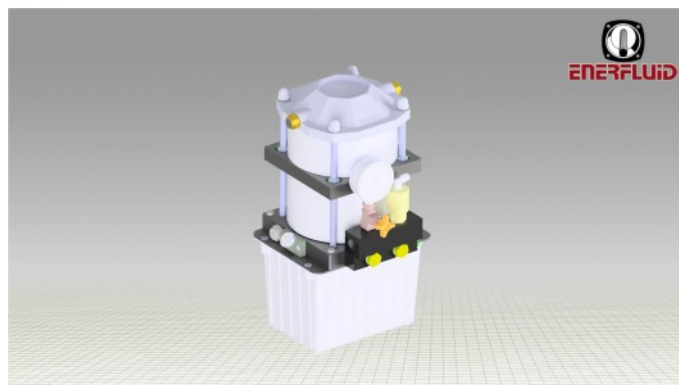
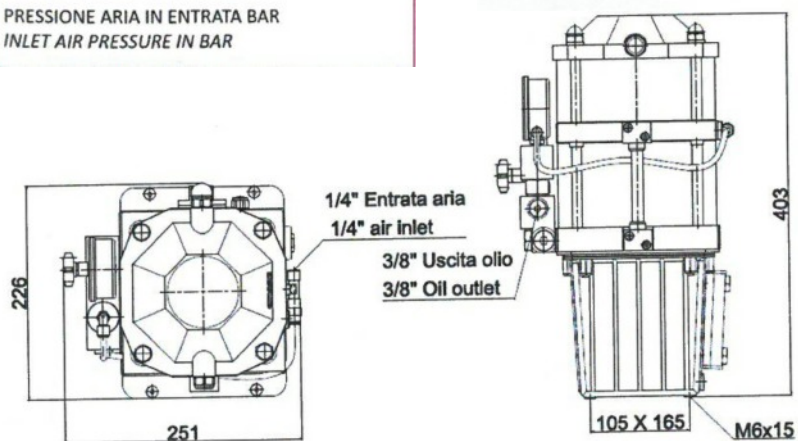
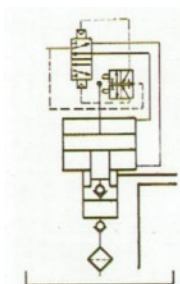

GENERAL CHARACTERISTICS AND APPLICATION:

As per base version, equipped also with single action valve and oil discharge with pneumatic pilotage.

COMMANDE PNEUMATIQUE:

A Port (G1 / 4) for pneumatic supply

It is recommended to use an upstream conditioning group

GENERALITES:

3 liters standard tank Capacity

Max oil flow: 2-3 l/min

Standard Pressure: 3 at 8 bars

equipped also with single action valve and oil discharge with pneumatic pilotage.

A: Feed max:8 bars min:3 bars

R: Oil discharge G3/8 Gas

U: Oil Outlet G3/8 Gas

Model	Pressure Ratio	Oil flow per cm ³	Oil flow at 6 bar l/min	Oil pressure with air	
				8 bars	6 bars
PMPO 160.24.36	1/24	24	3.25	192	144
PMPO 160.40.22	1/40	15	2	320	240
PMPO 160.52.17	1/52	11	1,5	416	312

Subject to technical modifications