

# MULTIPLIER POWER UNIT UPM 100

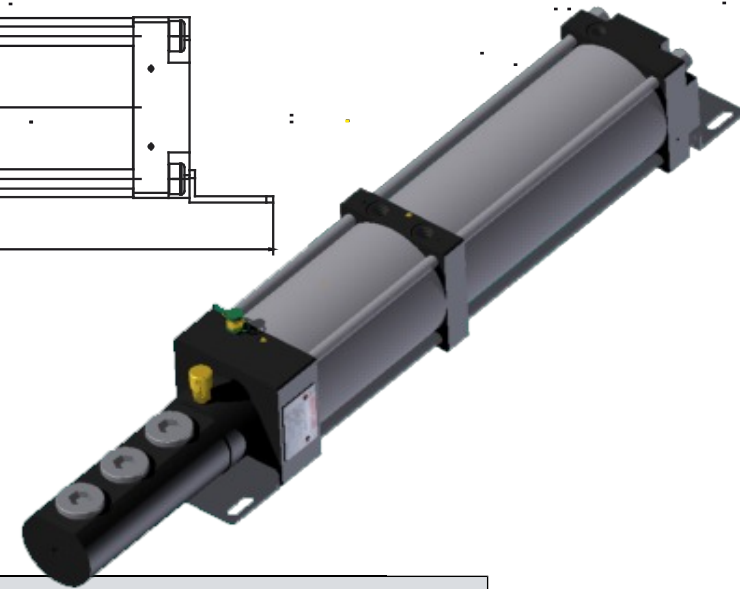
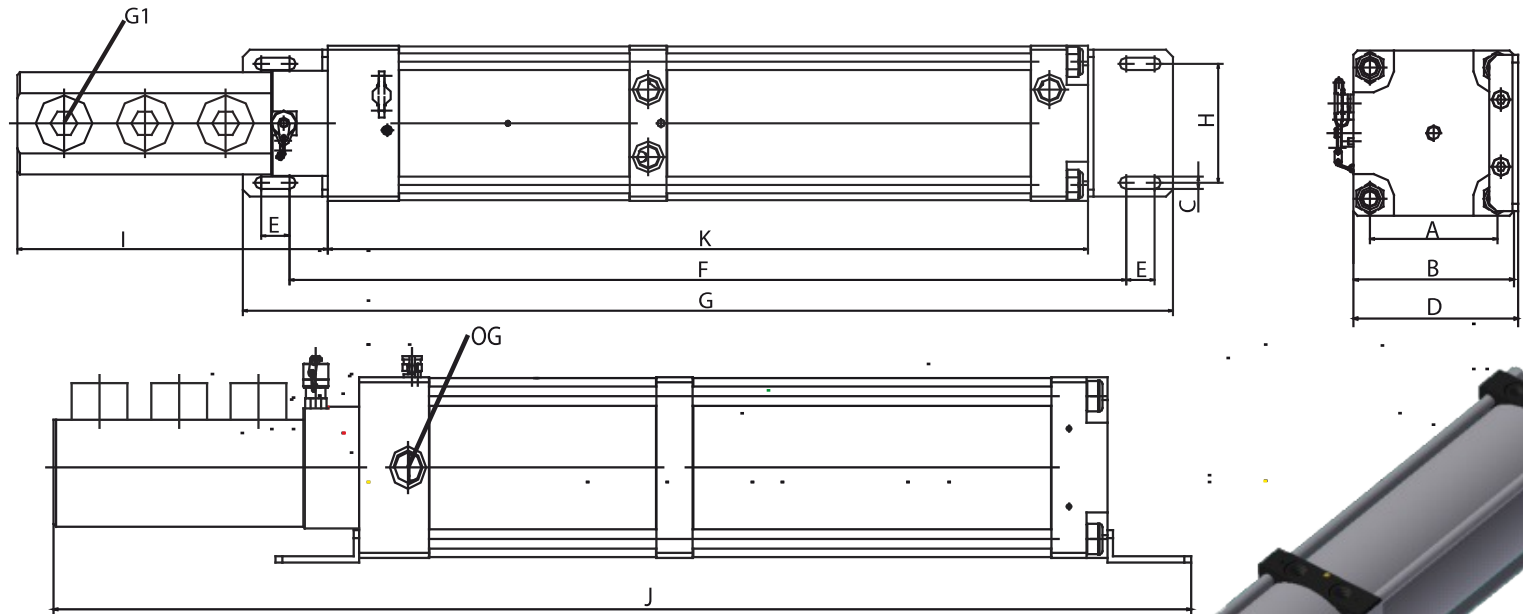

Model	Pressure Ratio	DIMENSIONS											
		A	B	C	D	E	F	G	H	I	J	K	OG
UPM 100 16 39	1/39	88	111	9	114	20	590	656	85	219	815	536	G1/2
UPM 100 12 22	1/69												

Under reserves of technical modifications