

FRAME C OXY CUT TYPE MEO

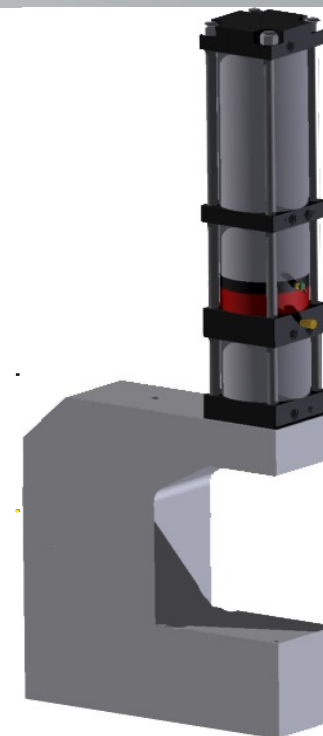
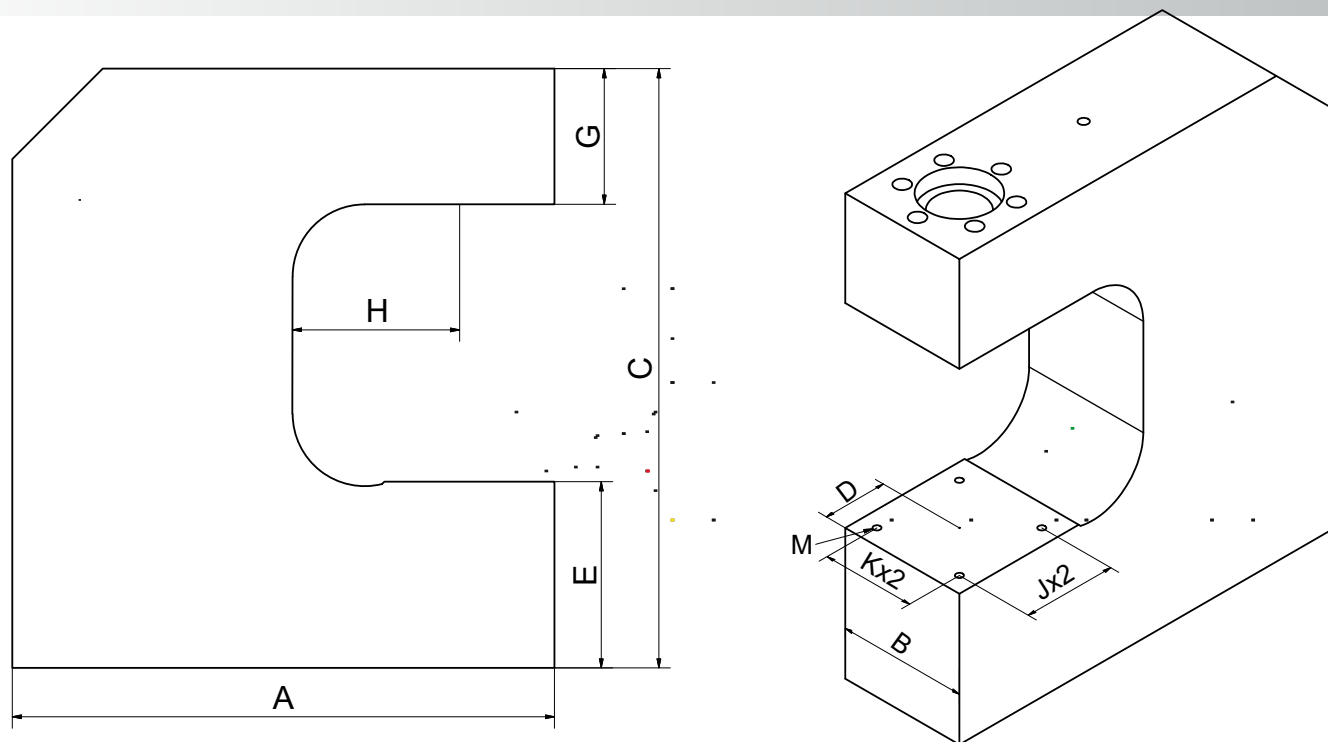

Modèle	Effort Max kN (t)	DIMENSIONS									
		A	B	C	D	E	G	H	J	K	M
MEO 40	40 (4)	370	90	514	50	125	60	150	40	35	M8
MEO 80	80 (8)	420	120	550	60	135	75	150	45	45	M10
MEO 150	150 (15)	550	150	601	75	185	85	200	60	60	M10
MEO 300	300 (30)	600	180	662	90	225	100	200	75	75	M12

Under reserves of technical modifications