

PRESSURE MULTIPLIERS TYPE 200

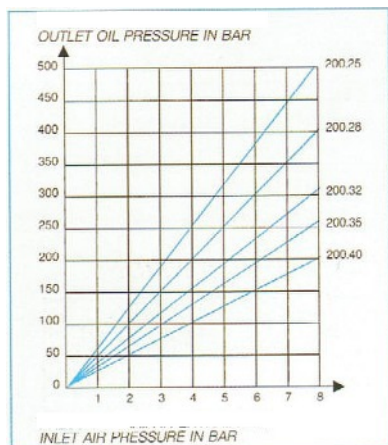

CURVE



APPLICATIONS:

Any application requiring the transfer of a capacity of oil determined in high pressure.

PNEUMATIC COMMAND:

H Opening G3/8 for version simple effect (RM)

H/H' Opening G3/8 for version double effet (RP)

it is recommended to choose the double effect when we look a stake In the rest frank.

HIGH PRESSURE HYDRAULIC

K opening (G1/4) intended mainly for the control (taken by pressure, Manometer, G Opening (G3/8) of power

MAJORITIES:

Assembly in all the position with reservoir of compensation (L) vertical or separated from multiplier.

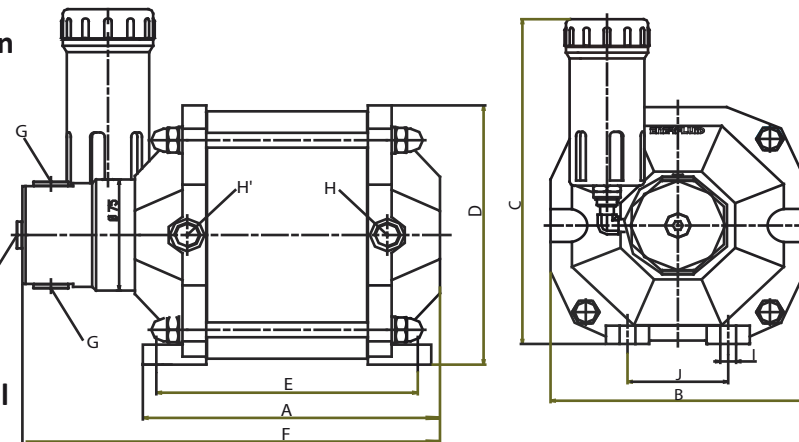

Modèle	Type de Return		Pressure Ratio	Oil pressure with		Oil flow per stroke cm3	DIMENSIONS																			
	RM	RP		8 bars	6 bars		A	B	C	D	E	F	G	H	I	J	K									
200.25.05	X		1/64	512	384	28	212	255	215	185	280	G3/8	G3/8	12	70	G1/4										
200.25.15						73											300	285	480							
200.28.05			1/51	408	306	36				185	280															
200.28.15						92				300	285						480									
200.32.05			1/39	312	234	47				185	280															
200.32.15						120				300	285						480									
200.35.05			1/32	256	192	56				185	280															
200.35.15						144				300	285						480									
200.40.05			1/25	200	150	25				185	280															
200.40.15						38				300	285						480									
200.25.05			X		1/64	512				384	20						212	255	215	185	280	G3/8	G3/8	12	70	G1/4
200.25.15											66															
200.28.05					1/51	408				306	25									185	280					
200.28.15											83									300	285					
200.32.05					1/39	312				234	33									185	280					
200.32.15											108									300	285					
200.35.05	1/32	256			192	39	185	280																		
200.35.15						130	300	285	480																	
200.40.05	1/25	200			150	51	185	280																		
200.40.15						169	300	285	480																	

Under reserves of technical modifications