

Hydraulic Speed Regulators Series 40 RPU.....



APPLICATIONS:

Any application requiring a control of the movements, the acceleration or stops.

PNEUMATIC COMMAND:

This regulator is coupled with a pneumatic cylinder standard

The regulation of the speed is made by the small thumb wheel which is on the regulator.

This model regulates in Traction (piston rod out regulation)

SYMBOL

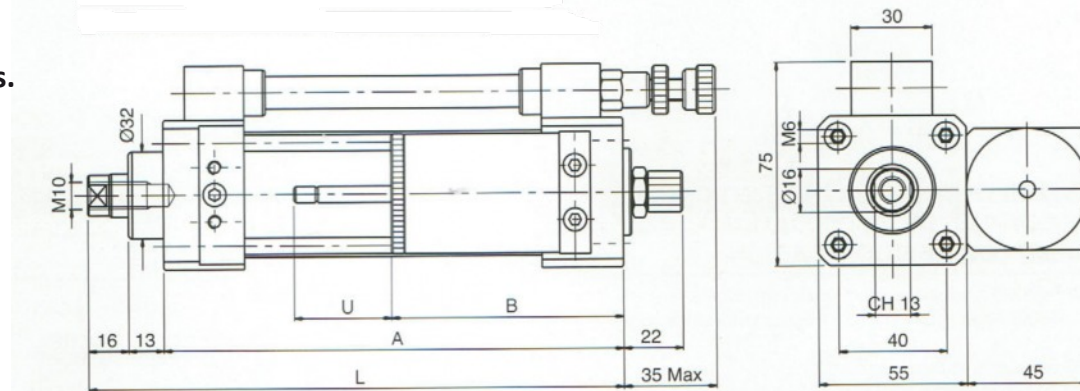
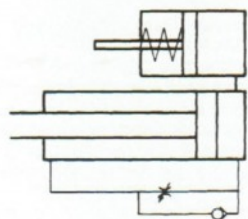

Model	Stroke mm	Dimensions			
		A	B	L	U
40.RPU.050.NO	50	136	105	165	32
40.RPU.100.NO	100	186		215	
40.RPU.150.NO	150	236	125	265	47
40.RPU.200.NO	200	286		315	
40.RPU.250.NO	250	336	150	365	67
40.RPU.300.NO	300	386		415	
40.RPU.350.NO	350	436	170	465	86
40.RPU.400.NO	400	486		515	

KEY OF CODES

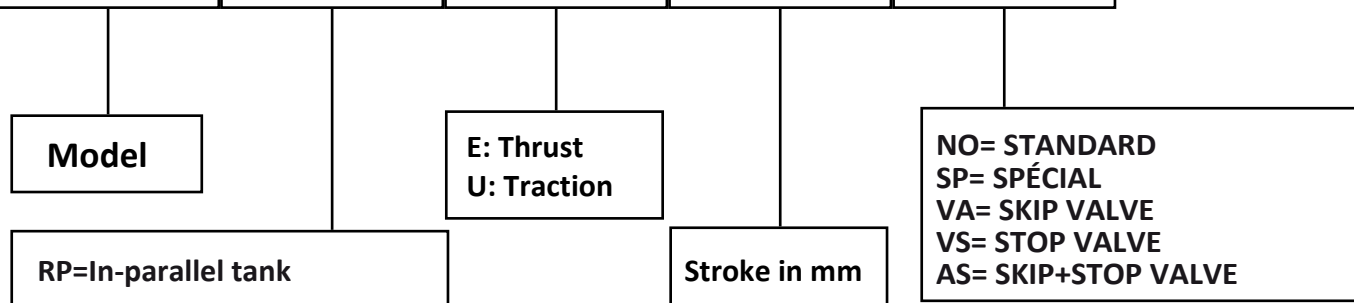
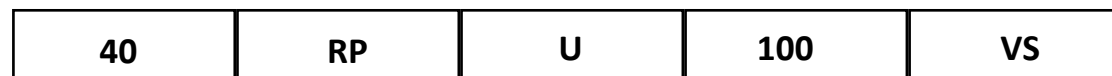

Under reserves of technical modifications